

PENNINGTON

Aquagarden™

beautifully simple water gardening

inpond 5-in-1

moving water & clarity

600

Congratulations on buying a
Pennington 5-in-1.

Manufactured with advanced technology to
create a clean and healthy pond for your fish.

IMPORTANT

Please attach proof of purchase to this manual and file in a safe place.

Please visit www.penningtonaquagarden.com
for helpful hints, tips, **how-to** videos and spares



Instructions español disponible descargar en:
www.PenningtonAquagarden.com

FOR INDOOR AND OUTDOOR USE IMPORTANT SAFETY INSTRUCTIONS

WARNING - TO REDUCE THE RISK OF ELECTRIC SHOCK, USE ONLY ON PORTABLE SELF-CONTAINED FOUNTAINS NO LARGER THAN 5 FEET IN ANY DIMENSION.

WARNING - RISK OF ELECTRIC SHOCK - THIS PUMP IS SUPPLIED WITH A GROUNDING CONDUCTOR AND GROUNDING TYPE ATTACHMENT PLUG. TO REDUCE THE RISK OF ELECTRIC SHOCK, BE CERTAIN THAT IT IS CONNECTED ONLY TO PROPERLY GROUNDED, GROUNDING-TYPE RECEPTACLE.

WARNING - TO REDUCE THE RISK OF ELECTRIC SHOCK, INSTALL ONLY ON A CIRCUIT PROTECTED BY A GROUND-FAULT CIRCUIT-INTERRUPTER (GFCI).

GROUNDING INSTRUCTION

WARNING - RISK OF ELECTRIC SHOCK - THIS PUMP IS SUPPLIED WITH A GROUNDING CONDUCTOR AND GROUNDING-TYPE ATTACHMENT PLUG. TO REDUCE THE RISK OF ELECTRIC SHOCK, BE CERTAIN THAT IT IS CONNECTED ONLY TO A PROPERLY GROUNDED, GROUNDING-TYPE RECEPTACLE.

WARNING - TO GUARD AGAINST INJURY, BASIC SAFETY PRECAUTIONS SHOULD BE OBSERVED, INCLUDING THE FOLLOWING:

- A) **READ AND FOLLOW ALL SAFETY INSTRUCTIONS.**
- B) **DANGER** - TO AVOID POSSIBLE ELECTRIC SHOCK, SPECIAL CARE SHOULD BE TAKEN SINCE WATER IS EMPLOYED AND INTENDED FOR FOUNTAINS, WATERFALLS, AND PONDS, WHICH ARE COMPLETELY SUBMERSED FOR PUMPING WATER AND ARE SUITABLE FOR OUTDOOR USE. FOR EACH OF THE FOLLOWING SITUATIONS, DO NOT ATTEMPT REPAIRS BY YOURSELF; RETURN THE APPLIANCE TO AN AUTHORIZED SERVICE FACILITY FOR SERVICE OR DISCARD THE APPLIANCE. IF THE APPLIANCE SHOWS ANY SIGN OF ABNORMAL WATER LEAKAGE, IMMEDIATELY UNPLUG IT FROM THE POWER SOURCE. DO NOT OPERATE ANY APPLIANCE IF IT HAS DAMAGED CORD OR PLUG, OR IF IT IS MALFUNCTIONING OR HAS BEEN DROPPED OR DAMAGED IN ANY MANNER.
- C) CLOSE SUPERVISION IS NECESSARY WHEN ANY APPLIANCE IS USED BY OR NEAR CHILDREN.
- D) TO AVOID INJURY, DO NOT CONTACT MOVING PARTS DIRECTLY.
- E) CAREFULLY EXAMINE THE PUMP AFTER INSTALLATION, IT SHOULD NOT BE ENERGIZED IF THERE IS WATER ON PARTS NOT INTENDED TO BE WET.
- F) ALWAYS UNPLUG AN APPLIANCE FROM AN OUTLET WHEN NOT IN USE, BEFORE PUTTING ON OR TAKING OFF PARTS, AND BEFORE CLEANING. NEVER YANK CORD TO PULL PLUG FROM OUTLET. GRASP THE PLUG AND PULL TO DISCONNECT.
- G) DO NOT USE AN APPLIANCE FOR OTHER THAN INTENDED USE.
- H) READ AND OBSERVE ALL THE IMPORTANT NOTICES ON THE APPLIANCE.
- I) DO NOT PUMP FLAMMABILITY OR HEATED LIQUIDS.
- J) **DO NOT RUN DRY.**
- K) DO NOT CONNECT TO ANY VOLTAGE OTHER THAN SHOWN ON THE PUMP.
- L) ENSURE THAT THE POWER SUPPLY CORD LOOPS BELOW THE ELECTRICAL OUTLET TO FORM A "DRIP LOOP". THIS WILL PREVENT WATER FROM RUNNING DOWN THE CORD INTO THE ELECTRIC OUTLET.

SAVE THESE INSTRUCTIONS

CONTENTS

Getting to know your Inpond 600	2
Parts Descriptions / spares codes - with exploded diagram	2,3 & 4
Pump performance / flow chart	5
Specification chart	5
Installation	6
Electrical Installation	6
Installing UVC	7 & 8
UVC Electrical Installation	9
Installing Inpond	10, 11, 12 & 13
Maintenance and cleaning	14,15,16 & 17
Cleaning	14
Step by Step guides	14 & 15
Routine Maintenance	16 & 17
Annual Maintenance	17
Winter storage	17
Troubleshooting	18,19 & 20
Troubleshooting and maximise performance	18,19 & 20
Faults - problem procedure	
Consumer advice contact details	20
	20
Guarantee	20 & 21

GETTING TO KNOW YOUR INPOND 600

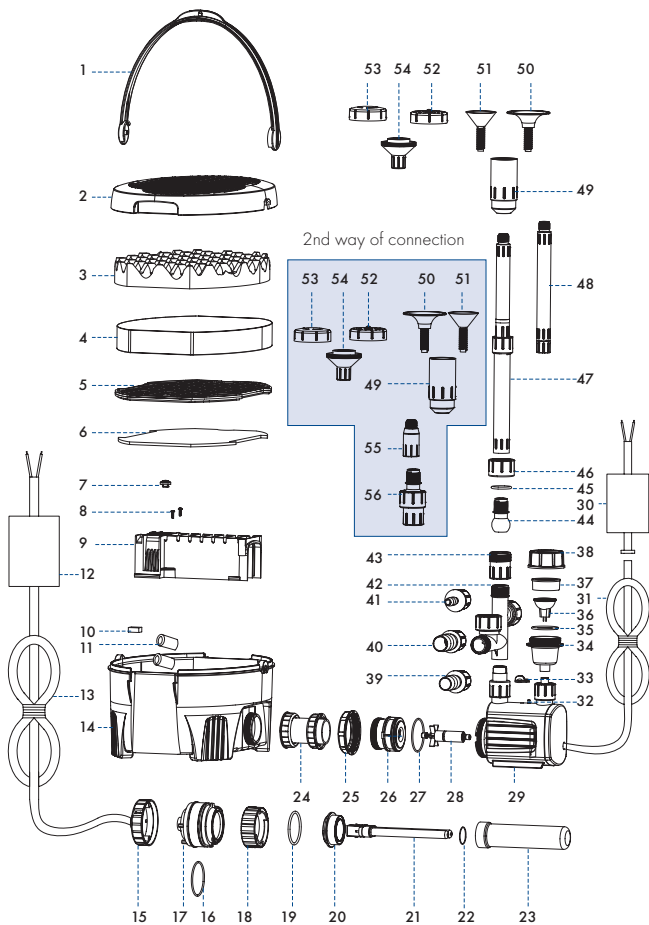

GETTING TO KNOW YOUR INPOND 600

No.	Part Description	Spare Code
1.	Locking Handle	N/A
2.	Filter Lid	N/A
3.	Coarse Foam	1051811
4.	Medium Foam	1051811
5.	Polymer Wool Cartridge	N/A
6.	Polymer Wool Pad	1051699
7.	UVC Viewing Window	N/A
8.	UVC Contact Chamber Screws	N/A
9.	UVC Contact Chamber	N/A
10.	UVC Magnet	N/A
11.	Ceramic Media	N/A
12.	IPX7 Starter UVC	N/A
13.	UVC Mains Cable	N/A
14.	Filter Body	N/A
15.	UVC Electronics & Cap	N/A
16.	UVC O ring	N/A
17.	UVC Body	N/A
18.	UVC Quartz Sleeve Yellow Lock Cap	N/A
19.	UVC Quartz sleeve O ring	N/A
20.	UVC Quartz sleeve Holder	N/A
21.	PL 9w UVC Lamp	N/A
22.	Lamp Rubber Holder	N/A
23.	9w Quartz Sleeve	N/A
24.	1 1/2" Connecting Pipe	N/A
25.	Pump Locking Nut	N/A
26.	1 1/2" Impellor Cover	N/A
27.	Pump O ring	N/A
28.	Impellor Complete	1051859
29.	Pump motor unit	N/A
30.	Low Voltage Transformer	N/A
31.	Pump Cable Low Voltage	N/A
32.	Light Level Sensor - Photo Sensor	N/A
33.	Optional Sensor Cover	N/A
34.	Automatic LED Spot Light Body	N/A
35.	Automatic LED Spot Light O ring	N/A
36.	LED Lamp 0.76w	1051866
37.	LED Lamp cover clear	N/A

GETTING TO KNOW YOUR INPOND 600

No.	Part Description	Spare Code
38.	LED Lamp Screw Cap	N/A
39.	18.75mm (3/4") Hose Fitting	N/A
40.	25mm (1") Hose Fitting	N/A
41.	12.5mm (1/2") Hose Fitting	N/A
42.	T-piece	N/A
43.	T-piece Connector	N/A
44.	Ball Joint	N/A
45.	Ball Joint O ring	N/A
46.	Extension Pipe Connector	N/A
47.	30cm Telescopic Extension pipe	N/A
48.	20cm Extension pipe	N/A
49.	Jet Housing	N/A
50.	Bell Jet	N/A
51.	Tulip Jet	N/A
52.	Daisy jet	N/A
53.	Triple Jet	N/A
54.	Jet Housing	N/A
55.	Fountain adapter	N/A
56.	Complete Ball Joint	N/A

GETTING TO KNOW YOUR INPOND





Pump performance / flow chart

	600
Voltage	120V 60hz
Watts	24w
Safety Rating	ETL/CE
Maximum Depth	4'9"
Maximum Lift	5'3"
Lift	Flow Rates
5'	37gal/hr
4'	106gal/hr
3'	181gal/hr
2'	242gal/hr
1'	299gal/hr
0'	369gal/hr
Flow is given at optimum rate	600

Tech Specification:

Pump	600
Max Flow	369 gal/hr
Max Head	5'3"
Mains Cable	16'
Watts	24w
LED	
Photo sensor activated	0.76w
UVC	600
Lamp	9w
Cable	16'
Voltage	120v
Hertz	60Hz
Safety Rating	ETL/CE
Wattage	12w

Specification chart

Filter Model	 Max pond size with Gold fish (over 2'6" average depth)	 Shallow gold fish pond (under 2'6" average depth)	 Pond with Koi (over 2'6" average depth)	 Shallow pond with Koi (under 2'6" average depth)	W UVC Model watts	O Recommended Hose Size Outlet
600	600 Gallons	450 Gallons	300 Gallons	225 Gallons	9W	1"

INSTALLATION

ELECTRICAL SAFETY INFORMATION: **Caution:** Household indoor and outdoor use.



WARNING - Risk of Electric Shock. Mount the unit at a height greater than 1 foot from the ground surface. Install only to covered Class A GFCI receptacle that has an enclosure that is weatherproof with the attachment plug cap inserted or removed.

The power supply must meet the specification of the product.

Inpond Pump

The electric cord is permanently connected and sealed in the motor body. If the supply cord is damaged the pump must not be used. Do not use the supply cord to lift the pump as this may cause damage.



WARNING - All Inpond models must be used with an GFCI. To reduce the risk of electric shock, connect only to a properly grounded, grounding-type receptacle. To reduce the risk of electric shock, install only on a circuit protected by a ground fault circuit interrupter (GFCI).

Do not remove the grounding pin from the power cord plug. This pump has been evaluated for use with fresh water only. Attention has been drawn to the fact that special rules may exist concerning the installation of your inpond. These pumps must not be used in swimming pools, or areas where people are in contact with the water. Always disconnect the power source whilst the equipment is being installed, repaired, maintained or handled.



WARNING - The Inpond pump is provided with a thermal cut out that temporarily switches off the pump in case of overheating and the pump may automatically restart. **WARNING -** Never run the inpond out of water for prolonged periods as this may cause irreparable damage. **WARNING - Risk of electric shock -** This inpond has not been investigated for use in swimming pools or marine areas.

GROUNDING INSTRUCTIONS - This appliance must be grounded. In the event of a malfunction or breakdown, grounding will reduce the risk of electric shock by providing a path of least resistance for electric current. The appliance is equipped with a cord having an appliance-grounding conductor and a grounding plug. The plug must be plugged into an appropriate outlet that is installed and grounded in accordance with all local codes and ordinances.



WARNING - Improper connection of the appliance-grounding conductor can result in a risk of electric shock. Check with a qualified electrician or service representative if you are in doubt whether the appliance is properly grounded. Do not modify the plug provided with the appliance: if it will not fit the outlet; have a proper outlet installed by a qualified technician.

UVC INSTALLATION



Warning - 1) Always turn off the power before any maintenance to the UVC section 2) Always view the UVC lamp through the viewing window on the UVC Chamber 3) Direct exposure to UVC light can damage your eyes and skin.



Caution - Inpond UVC has been fitted with a magnetic safety switch. 1) Do not remove unit with power turned on 2) Do not place near strong magnetic fields.

This product conforms with the applicable provisions of The Code of Federal Regulations (CFR) requirements including, Title 21, Chapter 1, Subchapter J, Radiological Health.

UVC Lamps & quartz sleeve maintenance

The UVC lamp must be replaced every six months / once a season. It is recommended that the lamp is replaced in the spring.

The Quartz sleeve can become coated in lime scale build up in hard water areas. This should be carefully removed from the quartz sleeve and cleaned with a soft cloth.

A wet test must be carried out after maintenance to ensure there are no leaks before the UVC is reconnected. pond/water feature.

Wet testing the UVC

IMPORTANT - A wet test of the UVC under operating conditions must be carried out before the UVC or electrical supply is installed. Connect the UVC to the Inpond following all installation instructions. After running for 24 hours check for leaks.

Testing/replacing the UVC lamp

IMPORTANT - Ensure that the mains supply is switched off and the power is isolated before removing the UVC cover.

See Page 8 for illustration

UVC INSTALLATION

1. Unlock the green UVC electronics cap.
2. Inspect the UVC cap and Quartz sleeve for water leaks.
3. Then unlock the yellow quartz sleeve end cap and unplug the lamp to replace if desired
4. If there are no signs of leakage reverse the procedure ensuring that the quartz sleeve O-ring is in place. See alignment diagram.
5. Ensure the yellow quartz sleeve cap and the green UVC electronics cap are firmly secured by making sure the two looked positions are in direct line of each other. See diagram on page 9, section 5.

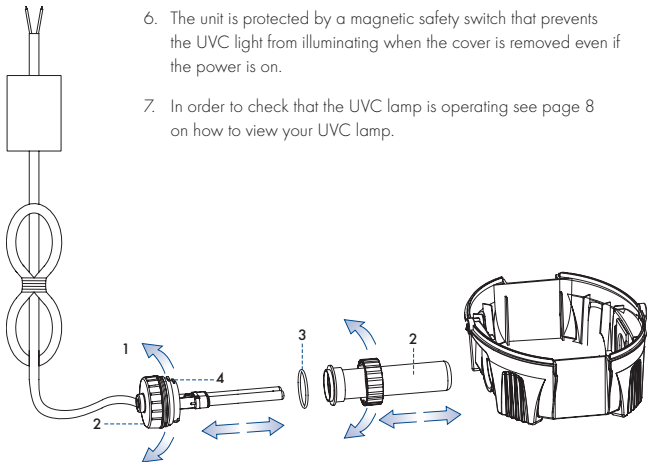

If there has been any damage to the unit please return to the point of purchase for inspection.

UVC ELECTRICAL INSTALLATION

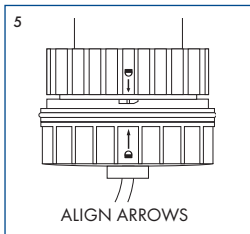

Danger - Ultra violet Radiation. Do not expose eyes to lamp rays. Disconnect power before servicing or replacing the lamp. READ THE INSTRUCTIONS

Electrical installation - UVC



Warning - To reduce the risk of electric shock, connect only to a grounded, grounding-type receptacle. To reduce the risk of electric shock, install only a circuit protected by a ground fault circuit interrupter (GFCI)

Attention has been drawn to the fact that special rules may exist concerning the installation of your Inpond UVC.

This UVC must not be used in swimming pools, or areas where people are in contact with the water.

Always disconnect the mains electricity supply whilst the equipment is being installed, repaired, maintained or handled.



WARNING: Electrical Safety

UVC warning: Dangerous Ultra Violet Radiation. The rays from the UVC lamp are harmful to eyes and skin.

Always turn off UVC electrical supply before any maintenance.

To protect the UVC starter; never immerse in water. Locate the UVC starter (Inpond 300 part 12 & Inpond 600 part 11) 3'2" minimum from pond edge.

INSTALLATION

Locating your Inpond

The Inpond pump and filter should be located on a firm and level base in the pond/water feature in a depth of at least 4", but no more than 4' 10" for the 300 model and 4' 9" for the 600 model.

Fountain

Place product in desired location.

Using the telescopic pipe adjust so the fountain head is above the surface of the pond.

Fountain height can now be adjusted, see 'Adjusting flow control' diagram below. See "Getting to know your Inpond" for parts and descriptions.

Bell Fountain

Adjust bell by moving head higher for small bell and lower for a wider bell shape.



Inpond 600

Adjusting Dual Control T Piece and telescopic riser pipe

1. Adjust height by unlocking collar then pushing or pulling 30cm telescopic riser pipe. Optional additional 20cm extensions can be added to increase the height.

2. Outlet Flow Control Valve

Supply water features, waterfalls and filters by adding 1" 3/4" 1/2" fittings and hose. Adjust flow by turning flow control valve.

3. Fountain Flow Control Valve

Adjust fountain jet flow by turning flow control valve.

4. Fountain Ball Joint

Adjust the collar of the ball joint to enable the extensions to be moved compensating for an uneven pond floor.

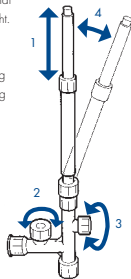

Tip: Ensure that any fountain or feature fitted does not empty water out of pond/water feature.

INSTALLATION

Convenient Installation

Inpond 600

FOUNTAIN OPTION

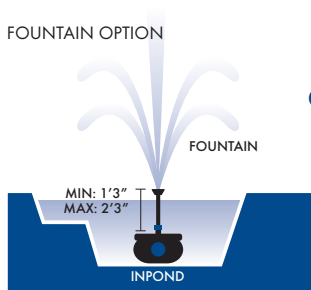

OR

FEATURE OPTION

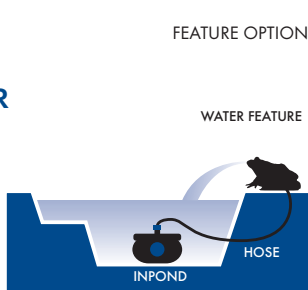

INPOND, FOUNTAIN AND/OR FEATURE OPTION

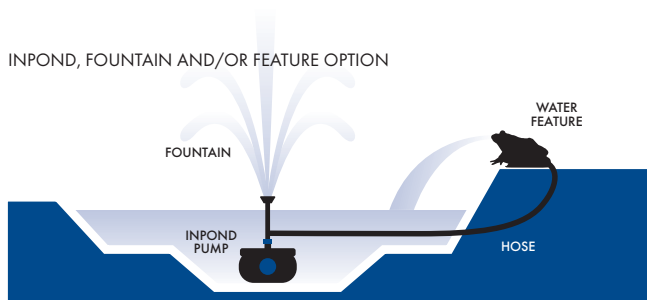

INSTALLATION

Inpond 600

INPOND 5 in 1 FILTER RUNS A FOUNTAIN, FEATURE AND LED SPOTLIGHT

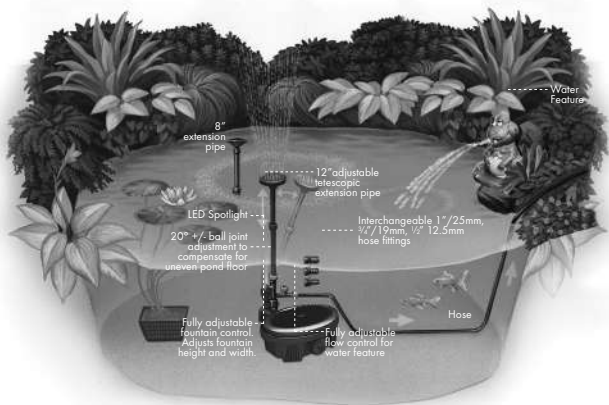

INSTALLATION

Waterfall Installation

Important

The outlet hose should be smooth bore (not corrugated) pipe installed over as short a distance as possible with no kinks or bends.

Connecting Outlet Hoses

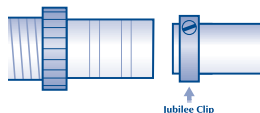

The recommended hose size for your Inpond Filter is stated in the filter performance and specification chart. On Page 5.

Always secure with a Jubilee clip

Warming the hose in a bucket of boiling water can aid fitting.

Use the shortest possible hose lengths to minimise flow restrictions.

Avoid folds and kinks in the hose, which will reduce flow and filter performance.

Installing the waterfall or feature

600

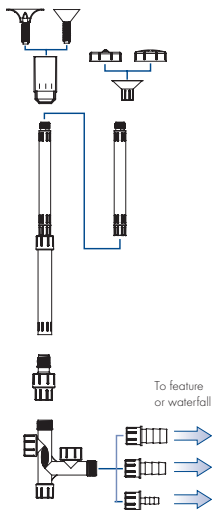

MAINTENANCE & CLEANING



IMPORTANT - Failure to carry out routine maintenance leaving the pump under reduced or no flow conditions for long periods will result in a shorter pump life and will invalidate the guarantee.

The Pennington Inpond pump is centrifugal with a magnetic impellor movement driven by a watertight synchronous motor. They require minimum cleaning, only periodic cleaning of the impellor is necessary.

Routine Maintenance

1. Switch off electricity
2. Remove Inpond from pond using carry handle (do not use the cables to lift the Inpond)

How it works - Flow detail

The water flows through the top of the filter cage down through the filter foams and ceramic media then through the UV chamber ready to exit via the pump.

Locking Handle

Doubles as a carry handle for easy removal from pond

Inlet Grills

High surface area, ideal for general pond USE

Course/Medium Foam

Open cell foam in two reducing grades catching dead algae, dirt and waste giving a crystal clear pond.

Green Water UV Clarifier

Built in light guarantees algae free clear water

Safety Switch

Built in automatic magnetic safety OFF switch for the UV

Automatic LED Spotlight

Saving time and money

Pump

Polymer Wool Pad Cartridge

Polishes the water quickly removing particles that create cloudiness

Ceramic Biomedia

Supports large populations of friendly bacteria, creating a clear and healthy pond

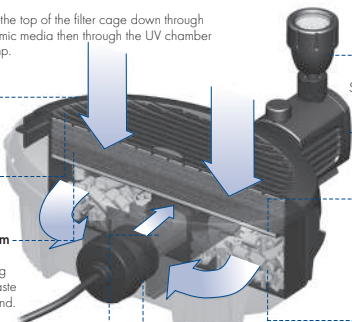

MAINTENANCE & CLEANING

Opening and locking filter handle

Easy lift integrated locking handle



1. Handle in the locked position



2. Handle is in the central position. This will enable the filter and pump to be carried in and out of the pond. *Ensure the filter is not carried by the pump cable.



3. Close handle down to open position



4. The handle is in the unlocked position allowing the filter media to be removed and cleaned.

Foams may be cleaned vigorously in a bucket of pond water.

Ceramic bio media

These will only need very occasional cleaning (once per year), but must be rinsed in pond water to prevent damaging the beneficial bacteria which help maintain a healthy pond.

Polymer wool cartridge

The polymer wool pad may be washed a limited number of times before it starts to lose efficiency and block rapidly.

Replacement packs of polymer wool are available from your retailer and are quick and easy to replace.

See page 15 On how to remove the cartridge easily from the Inpond.

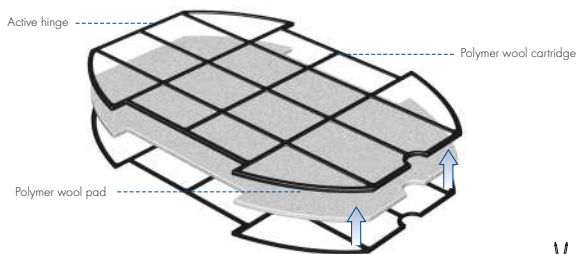

Removing led Lamp

Replacing or removing the lamp can be easily done by unscrewing the lamp screw cap, then the clear cover can come apart. Allowing the LED lamp to be disconnected. See getting to know your Inpond for part descriptions.

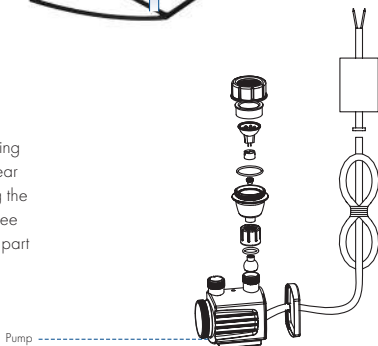

IMPORTANT - Ensure that the mains supply is switched off and the power isolated before removing the lamp cover.

MAINTENANCE & CLEANING

LED Automatic Photo Sensor

- detects when light levels are low/dusk

The LED automatic sensor is positioned on top of the motor body between the outlet and the lamp. Ensure this is kept clean from dirt and algae as it needs sufficient light to activate correctly.

This extremely efficient lamp uses less than 1 watt of electricity which automatically turns on at dusk and off at dawn.

Automatic LED spot light

Ball joint

LED automatic sensor

Pump

If the LED light is not required you can permanently remove the lamp. Inpond comes complete with a rubber cover that can be used to keep the LED light on permanently.
See instruction sticker on the pump for more information.



Annual maintenance of the filter

Check for wear. Once a year you should dismantle your Inpond. Dismantle the filter examining all the parts for wear or damage, replacing any parts showing obvious signs of wear and/or damage (see getting to know your filter for replacement codes and parts descriptions on pages 2, 3, 4 & 5)

Annual maintenance of the pump

Check for wear. Once a year you should service your pump. Dismantle pump and examine all parts for wear or damage, replacing any parts that show obvious wear and/or damage (see getting to know your Inpond for parts/description and replacement codes). Particular care should be taken to examine the cable entry points.

Annual maintenance of the UVC

Check for wear. Once a year you should dismantle your Inpond UVC section. Ensure you have disconnected the mains supply before carrying out any maintenance or cleaning. Dismantle the UVC containing all the parts for wear and damage, replacing any parts that show obvious signs of wear and damage (see getting to know your Inpond for parts/description and replacement codes).

Winter Storage

The Inpond can be run in the pond during the winter but care should be taken to ensure that it is fully immersed and cannot freeze solid. If the Inpond is not used during the winter follow the annual maintenance procedure and store frost-free in the house or garage until spring.

Inpond Filter

Cloudy/brown water

- The flow rate / pond turnover is too high or too low. Check that you have correctly calculated the pond volume and that pump flow rate is within limits.
- The filter is not being supplied with water 24 hours a day. Do not turn off your Inpond. Continuous running is needed to maintain a clean and healthy pond.
- The filter foam pads are insufficiently blocked to trap the fine waste.
- The water is extremely dirty, remove pond waste and leaves - carry out a partial water change.
- Filter is incorrectly sized - refer to filter performance and specification chart.
- The filter foams have not been positioned or replaced correctly, ensure that the foams fit tightly within the filter chamber.

UVC leaks

- Check that the UVC O-ring has been correctly assembled.
- Check that the UVC cap is correctly locked with the yellow quartz sleeve section. Arrows on both caps should be correctly aligned when fitted. See page 8 on how to correctly install and remove UVC section.

Inpond Pump

Problem

Low flow from pump

1. Follow routine cleaning procedure if no improvement.
2. Follow monthly cleaning procedure.
3. Ensure pipe work is not blocked, leaking or is laid so that it gets crushed or kinked.
4. Keep the height that water is to be pumped from the water surface (called Head) to a minimum. The higher the head the lower the flow rate and the more wear on the pump.
5. Use the largest diameter, smoothest bore pond hose over the shortest distance and keep hose fittings to a minimum. This removes frictional loss of flow and so increases pump flow rates.

TROUBLESHOOTING

Poor Fountain performance

- Reduced height.
- Jets blocked.
Clean flow adjusters and fountain head. Wash under a tap or hose. Pond Pump Cleaner should be used to remove lime scale build-up/waste (see diagram) for improved results.

No flow from pump

1. Check power supply is on.
2. Check fuse and wiring (SEE ELECTRICAL INSTALLATION).
3. Follow low flow procedure as above.

If none of the above works contact Pennington customer marketing Department (See Faults problem procedure Page 20).

Green water

- Settlement test the water to ensure that there is no sediment suspended in the water. If there is, follow the brown cloudy water troubleshooting guide.
- In order to check that the UVC lamp is operating: Open the filter unit (see page 15) remove the filter foams and cartridge. Positioned on top of the yellow UVC contact chamber will be a round viewing window where you should see a faint blue light. This operation may need to be carried out at dusk as UVC lamps emit a dim blue light under normal operation. Turning the lamp on and off may aid visual identification. (Ensure the UVC lamp is not more than 6 months old).
- The UVC may be working effectively but the filter foam/media is too clean and is unable to remove the fine coagulated waste.
- The filter is too small for the pond, check your filter selection chart.
- The UVC quartz sleeve is dirty or coated in lime scale. Gently remove the quartz sleeve and clean.
- Follow all cloudy water trouble shooting points.

DAISY

To clean, remove head and rinse.

Or in hard water areas, use Pond Pump Cleaner



TROUBLESHOOTING & IMPORTANT

UVC light not illuminated

- Check all fuses / RCD and electrical connections follow electrical installation

Faults - Problem Procedure

Before returning your Inpond to your dealer or contacting our Consumer Advice Department, please carry out the following steps. This will solve most problems quickly and easily.

1. Ensure electrical procedures have been followed fully. Check fuses and any cable connectors/switch boxes.
2. (a) Follow routine maintenance procedure fully. (b) Check location and connecting your pump details including flow rates. (c) Ensure that your pond volume and pump flow rate meet the maximum pond size recommended for the filter model on the filter performance and specification chart. (d) Follow troubleshooting guide.
3. If there is a mechanical breakdown of the filter or UVC, return to the point of purchase for inspection and advice (You will need proof of purchase).

Guarantee

UV & FILTER

This product is guaranteed against defects in material and workmanship for 2 years from the date of purchase, under normal usage. The guarantee DOES NOT APPLY in case of improper use, negligence, lack of maintenance or accidental damage to either the filter or UVC. If the filter or UVC fails due to a manufacturing fault within this period it will be either repaired or replaced free of charge. Liability is limited to replacement of the faulty product only; no other costs will be reimbursed. The guarantee is not transferable and does not affect your statutory rights. This guarantee does not confer any rights other than those expressly set out above. This guarantee does not cover the filter foams or UVC bulb, which will need replacing when worn or every 6 months. If any parts are needed, spares are available from your retailer.

IMPORTANT

PUMP & LIGHT

This product is guaranteed against defects in material and workmanship for 2 years from date of purchase, under normal usage. This guarantee DOES NOT APPLY in case of improper use, negligence, lack of maintenance or accidental damage either to the pump or the impeller shaft. If the pump fails due to a manufacturing fault within this period it will be either repaired or replaced free of charge. Liability is limited to replacement of the faulty product only, no other costs will be reimbursed. The guarantee is not transferable and does not affect your statutory rights. This guarantee does not confer any rights other than those expressly set out above. Excludes the pump impellor & LED lamp which may require replacing annually. If any parts need replacing, spares are available from your retailer.

Clearwater Guarantee

The Clearwater guarantee will be honoured for 1 year after proof of purchase. Clearwater is guaranteed to a depth of 3'2", so that fish are clearly visible.

Clearwater is guaranteed provided:

- You follow all instructions as above.
- Your filter is within the performance guidelines stated.
- You consult the Pennington customer marketing department and follow any advice to correct the situation. See details below. Refunds can only be authorised by Pennington.

Consumer Advice contact details

Pennington

1280 Atlanta Hwy.

Madison,

GA 30650

Tel: 1-800-285-7333

www.penningtonaquagarden.com



Aquagarden products by Pennington have been exclusively designed in partnership with Interpet UK a Leading British water garden company

Pennington,
1280 Atalanta Hwy, Madison.
GA 30650
www.PenningtonAquagarden.com

Leaflet Code:19/12/2016